

# CHALLENGER AC-evo

Expert in long distances

Capacity (kg): 1500 - 2000    Lifting Height (mm): 200

## CHALLENGER AC-evo

The ideal solution to handle the pallets in large warehouses where a high transfer speed is necessary to cover long distances.

The CHALLENGER is equipped with a folding platform and lateral safety boards to allow the operator to ride the truck in complete safety while reducing operator fatigue.

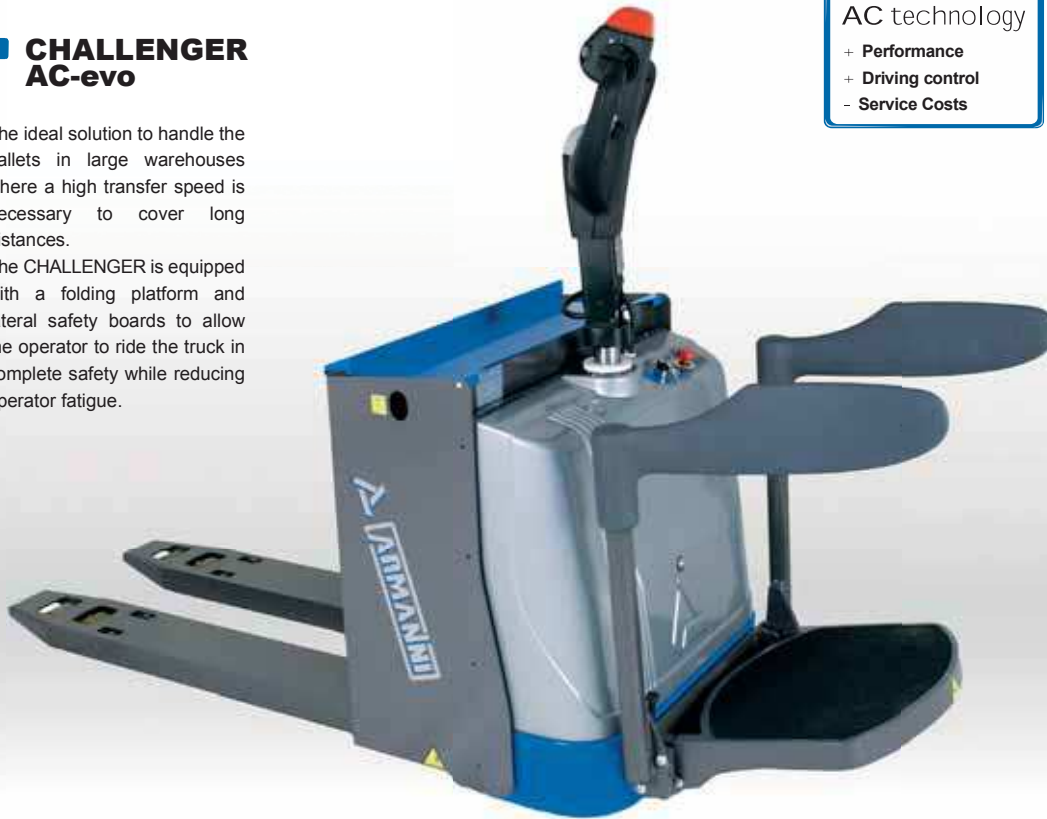

### AC technology

- + Performance
- + Driving control
- Service Costs

## POWERED PALLET TRUCKS

Features in detail: \_\_\_\_\_



### MAXIMUM AUTONOMY:

Powered by 24V industrial batteries with capacities to 270 Ah. A battery charger is built-in to the stacker control housing and includes a 220VAC power cord.



### SAFE SPEED:

High torque driving wheel is enhanced for high speeds (8 Km/h). Operator platform and side boards offer complete safety for high speed operation.

# SKIPPER AC-evo | SKIPPER PLUS AC-evo

Low and average pick-up

Capacity (kg): 1500 - 2500 - 3000    Lifting Height (mm): 200

## SKIPPER AC-evo

The operator's platform with ergonomic cushioned back rest is compact and easy to drive for goods picking or partial loads at various locations.

SKIPPER trucks are offered with custom forks for special loads or handling two pallets for even more efficient operation.

### AC technology

- + Performance
- + Driving control
- Service Costs



## SKIPPER PLUS AC-evo

Lifting platform version allows the operator to pick goods at increased heights.

## POWERED PALLET TRUCKS

Features in detail: \_\_\_\_\_



Pick up goods at floor level with driver on-board.



Pick up goods at higher levels by lifting the operator.



# CHALLENGER AC-evo

model		150/200	200/200
Q	Kg	1500	2000
C	mm	600	600
I	mm	1150	1150
L	mm	1810	1810
X	mm	180	180
X2	mm	295	295
Y	mm	1335	1335
L2	mm	660	660
M	mm	540	540
N	mm	170	170
h1	mm	1440	1440
h3	mm	200	200
B	mm	750	750
WA	mm	1660	1660
WA*	mm	2040	2040

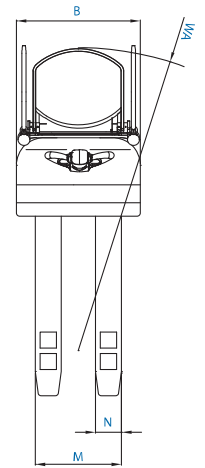
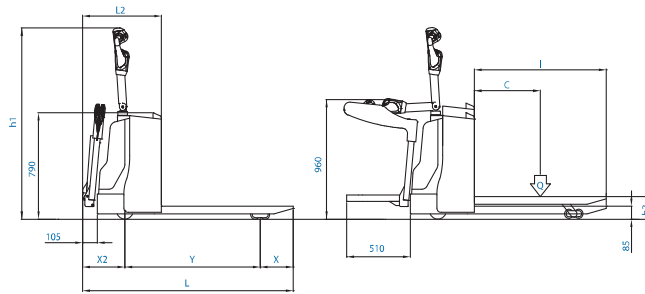

## STANDARD EQUIPMENT

- AC three-phase technology traction motors • Electronic battery charger 24V 50A with microprocessor • Forks control by push-buttons • Electric end stroke • Proof-seal bearings with pins with self lubricating sintered bushings • Electromagnetic parking brake • Braking in release contra flow • High-frequency electronic plant 24V with separated excitation with braking in release contra flow • Exhausted battery warning-indicator • Faster ratio motor wheel 24V 1700W • Folding footboard for operator with side guards with speed reduction switch • Side wheels with extra-heavy castors • Tandem fork rollers • DR-EVO Steering • Safety components • Traction Battery 24V from 240 Ah to 270 Ah

# SKIPPER AC-evo

model		150/200	200/200	250/200	300/200
Q	Kg	1500	2000	2500	3000
C	mm	600	600	600	600
I	mm	1150	1150	1150	1150
L	mm	2150	2150	2150	2150
X	mm	180	180	180	180
X2	mm	190	190	190	190
Y	mm	1780	1780	1780	1780
L2	mm	555	555	555	555
M	mm	540	540	540	540
N	mm	170	170	170	170
h1	mm	1440	1440	1440	1440
h3	mm	200	200	200	200
B	mm	750	750	750	750
WA	mm	2000	2000	2000	2000

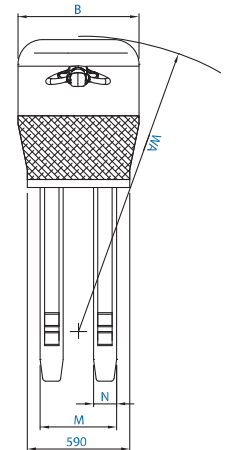
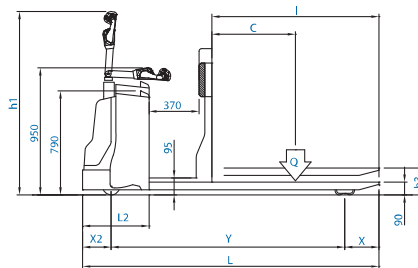

## STANDARD EQUIPMENT

- AC three-phase technology traction motors • Electronic battery charger 24V 20A with microprocessor • Forks control by push-buttons • Electric end stroke • Proof-seal bearings with pins with self lubricating sintered bushings • Electromagnetic parking brake • Braking in release contra flow • High-frequency electronic plant 24V with separated excitation with braking in release contra flow • Footboard for operator • Faster ratio motor wheel 24V 1700W • Side wheels with extra-heavy castors • Tandem fork rollers • DR-EVO Steering • Safety components • Traction Battery 24V from 160 Ah to 270 Ah

# SKIPPER PLUS AC-evo

model		150/200	200/200	250/200	300/200
Q	Kg	1500	2000	2500	3000
C	mm	600	600	600	600
I	mm	1150	1150	1150	1150
L	mm	2150	2150	2150	2150
X	mm	180	180	180	180
X2	mm	190	190	190	190
Y	mm	1780	1780	1780	1780
L2	mm	555	555	555	555
M	mm	540	540	540	540
N	mm	170	170	170	170
h1	mm	1090	1090	1090	1090
h3	mm	200	200	200	200
B	mm	750	750	750	750
WA	mm	2000	2000	2000	2000

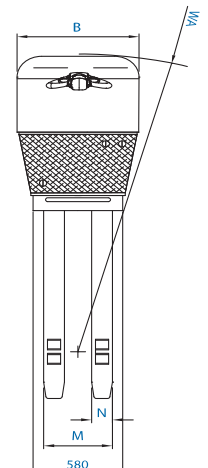
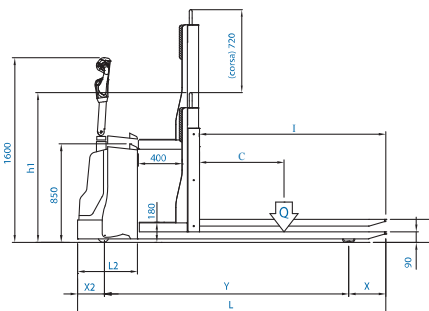

## STANDARD EQUIPMENT

- AC threephase technology traction motors • Electronic battery charger 24V 20A with microprocessor • Forks control by push-buttons • Electric end stroke • Proof-seal bearings with pins with self lubricating sintered bushings • Electromagnetic parking brake • Braking in release contra flow • High-frequency electronic plant 24V with separated excitation with braking in release contra flow • Footboard lifting by foot/hand push buttons • Faster ratio motor wheel 24V 1700W • Side wheels with extra-heavy castors • Tandem fork rollers • DR-EVO Steering • Safety components • Traction Battery 24V from 160 Ah to 270 Ah