

PX20/PPX20

Electric Low Lift Trucks
2.000 kg

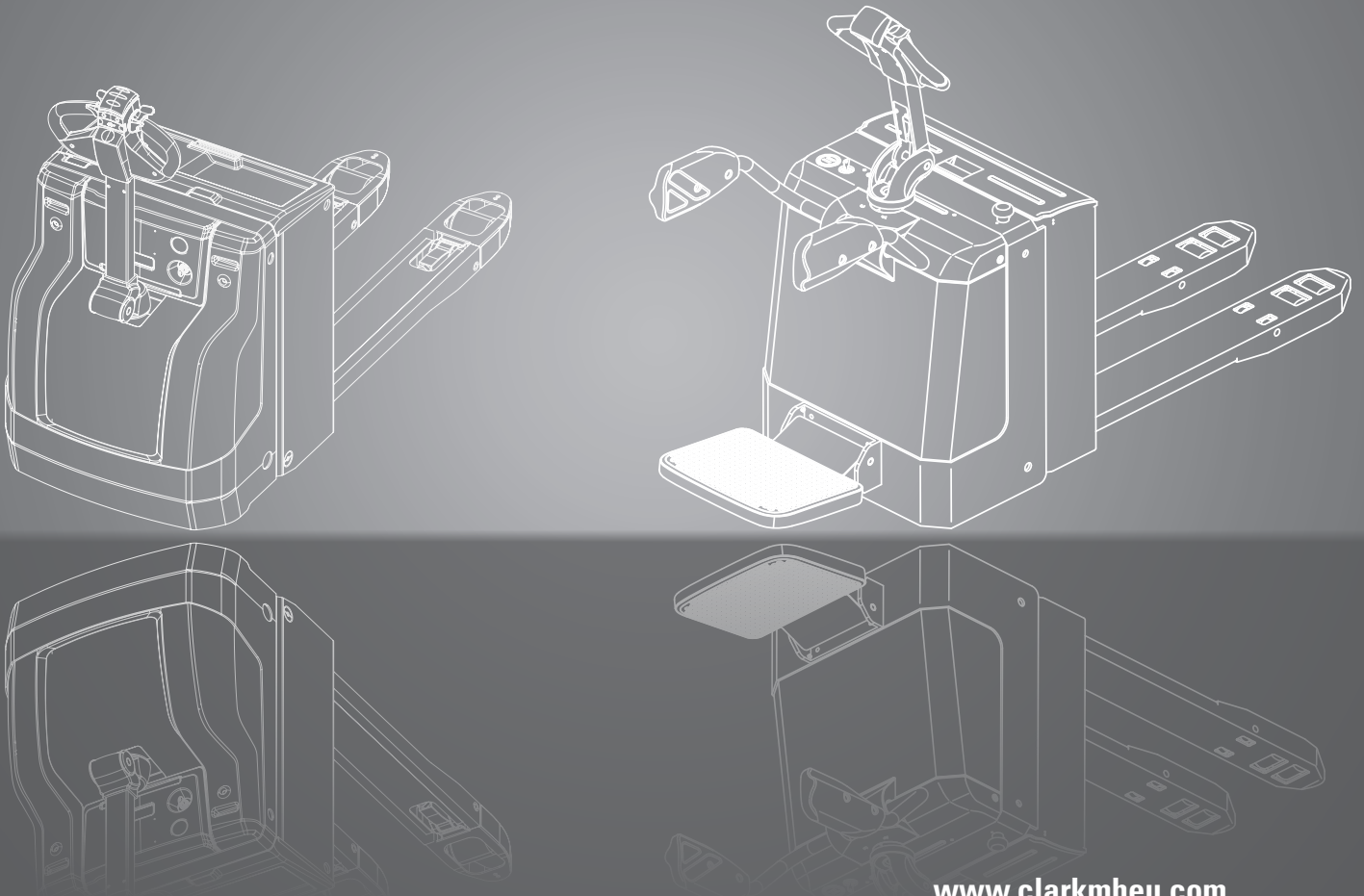

DIMENSIONS

PX20

$$R_h = \sqrt{x^2 + \left(\frac{b_{12}}{2}\right)^2}$$

$$A_{st} = W_a + l_6 - x + a \text{ if } R_h < W_a$$

$$A_{st} = R_h + l_6 - x + a \text{ if } R_h > W_a$$

A = Brake zone
B = Drive zone

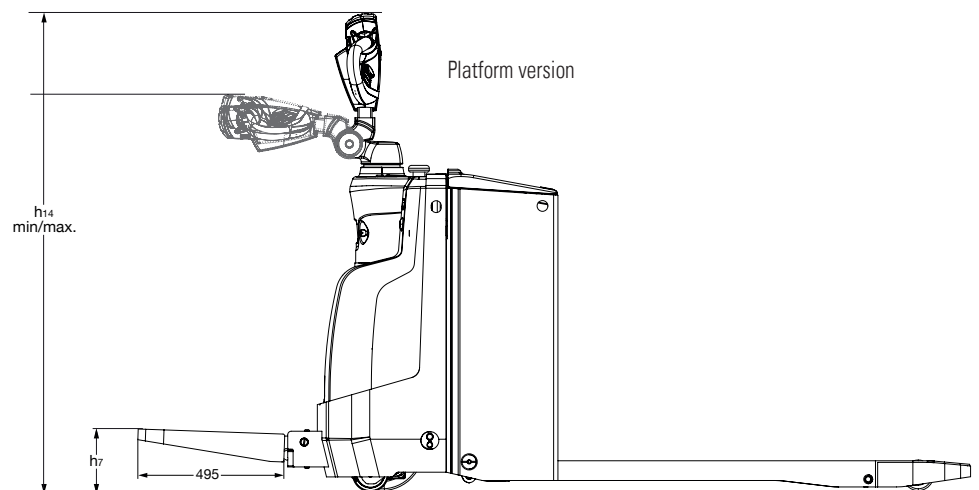
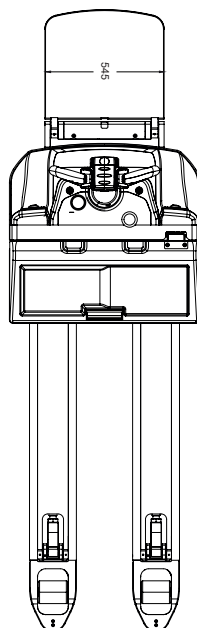
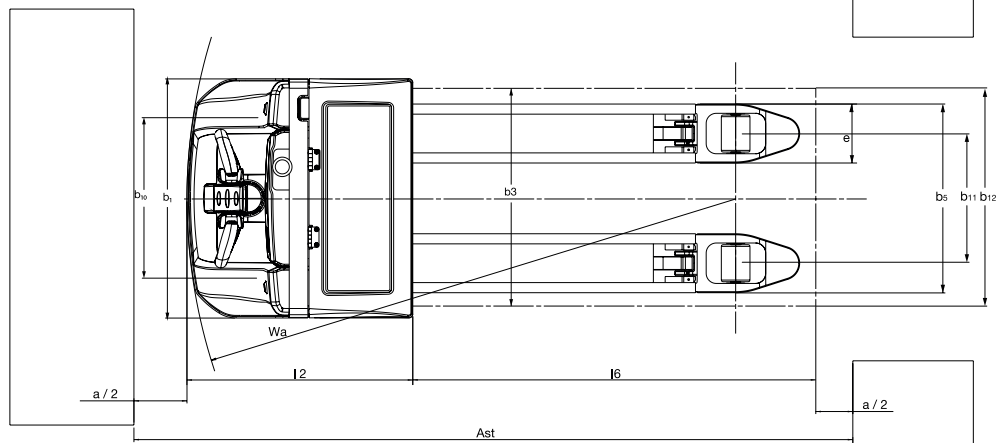
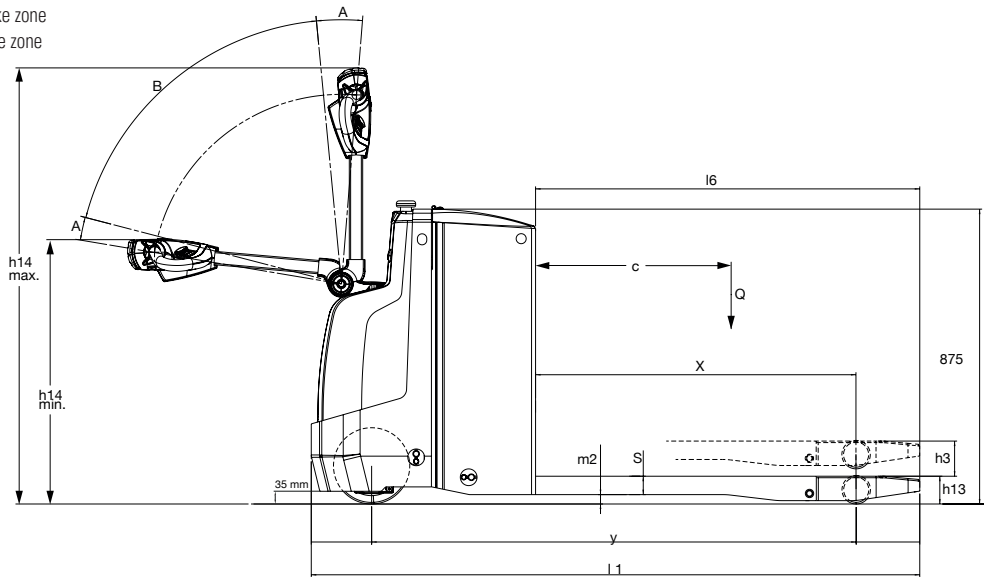

For corresponding data see specification chart.

SPECIFICATIONS

Product Specifications acc. to VDI 2198

1.1 Manufacturer (Abbreviation)		CLARK	CLARK	CLARK	
Specifications	1.2 Manufacturer's designation	PX20	PPX20	PPXS20	
	1.3 Drive	24V Electric	24V Electric	24V Electric	
	1.4 Operator type	Pedestrian	Stand-on/Pedestrian	Stand-on/Pedestrian	
	1.5 Rated capacity/rated load	Q (kg)	2000	2000	2000
	1.6 Load centre distance	c (mm)	600	600	600
	1.8 Load distance	x (mm)	1005	916	916
	1.9 Wheelbase	y (mm)	1356	1418	1418
Weight	2.1 Service weight incl. battery (see 6.5)	kg	515	670	670
	2.2 Axle loading, laden front/rear	kg	855/1660	1066/1604	1066/1604
	2.3 Axle loading, unladen front/rear	kg	407/108	546/124	546/124
Tyres, Chassis	3.1 Tyres		Polyurethane	Polyurethane	Polyurethane
	3.2 Tyre size, front		Ø 230x82	Ø 230x75	Ø 230x75
	3.3 Tyre size, rear		Ø 85x110/Ø 85x70	Ø 83x115/Ø 85x70	Ø 83x115/Ø 85x70
	3.4 Additional wheels (dimensions)		Ø 100x40	Ø 130x60	Ø 130x60
	3.5 Wheels, number front/rear (x = driven wheels)		1x +2/2 or 4	1x +2/2 or 4	1x +2/2 or 4
	3.6 Tread, front	b10 (mm)	490	510	510
	3.7 Tread, rear	b11 (mm)	385	370	370
Dimensions	4.4 Lift	h3 (mm)	130	125	125
	4.4 Lift height	h3 + h13 (mm)	215	210	210
	4.8 Stand height (optional platform for PX20)	h7 (mm)	160	200	200
	4.9 Height tiller in driving position min./max.	h14 (mm)	796/1219	-	-
	4.9 Height tiller in driving position min./max. (w/ platform)	(mm)	1066/1290	1150/1470	1150/1470
	4.15 Height, lowered	h13 (mm)	85	85	85
	4.19 Overall length	l1 (mm)	1692	1860	1860
	4.20 Length to face of forks	l2 (mm)	532	710	710
	4.21 Overall width	b1 (mm)	710	730	730
	4.22 Fork dimensions	s • e • l (mm)	55x175x1150	55x170x1150	55x170x1150
	4.25 Distance between fork-arms	b5 (mm)	560	540	540
	4.32 Ground clearance, centre of wheelbase	m2 (mm)	28	30	30
	4.33 Aisle width for pallets 1000 x 1200 sideways	Ast (mm)	1731	1984	1984
4.34 Aisle width for pallets 800 x 1200 lengthways	Ast (mm)	1931	2184	2184	
4.35 Turning radius	Wa (mm)	1536	1700	1700	
Performance	5.1 Travel speed, laden/unladen	km/h	6/6	6.5/8.5	9.5/12
	5.2 Lift speed, laden/unladen	m/s	0.04/0.05	0.05/0.06	0.05/0.06
	5.3 Lowering speed, laden/unladen	%	0.05/0.05	0.03/0.04	0.03/0.04
	5.8 Max. gradeability, laden/unladen *1		8/20	8/16	8/16
	5.10 Service brake		Electric	Electric	Electric
Electrics	6.1 Drive motor rating S2 60 min	kW	1.2	1.5	1.5
	6.2 Lift motor rating at S3 15 %	kW	1.2	0.84	0.84
	6.3 Battery acc. to DIN 43531/35/36 A, B, C, no		Option	DIN 43535 B	DIN 43535 B
	6.4 Battery voltage/nominal capacity	Ah/5hr	24V/150 (250/375Ah)	24V/250 (375Ah)	24V/250 (375Ah)
	6.5 Battery weight	kg	151	212	212
	6.6 Energy consumption acc. to VDI cycle	kWh/h	-	-	-
	- Battery type		Traction battery	Traction battery	Traction battery
	8.1 Type of drive unit		AC	AC	AC
10.5 Steering design		Mechanical	Mechanical	Electric servo steering	
Misc.	10.7 Sound pressure level at the driver's seat acc. to EN 12053	dB(A)	63	< 60	< 60

*1) At friction coefficient $\mu=0.6$ with 1.6 km/h

PRODUCT DESCRIPTION

The CLARK low lift pallet trucks PX20 and PPX(S)20 are robust value asset low lift trucks for industrial applications. These trucks are constructed following the Built To Last® principle. Whether for loading and unloading lorries or the transportation of heavy materials in a warehouse environment, the CLARK storage technology is designed for tough applications. These trucks can be fitted with batteries up to 375Ah. The side battery removal system allows for multiple shift rotation applications.

Productivity

All operation functions for lifting, lowering and driving are positioned in an ergonomic safety tiller handle with easy to reach switches. This allows the operator to concentrate solely on the conveyance process.

With the tiller arm in the vertical position, by using an optional switch the truck can be used for manoeuvring in confined spaces.

Reliability

The PX20/PPX(S)20 range is the result of CLARK's rich history as a developer and manufacturer of robust, reliable and long-lasting forklifts following the Built To Last® principle.

For the construction of the PX/PPX(S) range, CLARK used proven component materials and a sound build to ensure a long useful life, high performance and safety.

Battery compartment and Charging Technology

The robust mono-piece frames are available in different configurations. Three different battery compartment sizes are available for the PX20:

- Battery compartment (small) for 150Ah
- Battery compartment (medium) for 250Ah
- Battery compartment (large) for 375Ah

Even more flexible usage with optional integrated charger for the PX20 using a standard power socket.

The side battery removal option is also available in combination with a large battery compartment.

The PPX(S)20 range has two available battery size compartments:

- Battery compartment (standard) for 225Ah or 250Ah
- Battery compartment (large) for 375Ah

The side battery removal option is also available for the PPX(S)20 for both battery size compartments.

Optional PIN Code Activation (PX20)

With a four-digit PIN, the PX20 can be activated without an ignition key. Programmable automatic shutdown function also prevents unauthorised usage.

Driving characteristics such as acceleration, maximum speed or braking response can be set individually for each PIN code (up to 25 PIN codes can be saved with different driving parameters) and allows the PX20 to be adapted to the most diverse requirements.

Operator Platform

The foldable operator platform, an optional extra for the PX20 and standard for the PPX(S)20 increases both safety and comfort.

The platform has a heavy duty textured and non-slip surface and provides optimum comfort and additional suspension. The low level standing height makes it easy to get on and off the unit during operation.

If the driver steps off the platform, the unit automatically switches to standby mode and the unit can no longer be operated.

DIMENSIONS

PPX(S)20

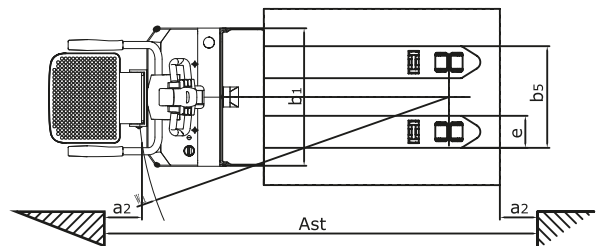
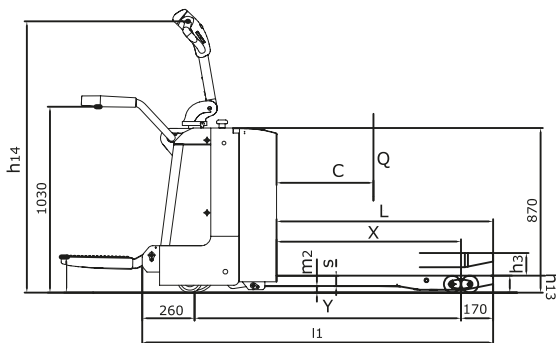

GENERAL DATA

PPX(S)20/PX20

The CLARK PX range includes three low lift truck models. The PX20 which is an extremely robust low lift truck has a maximum speed of 6 km/h. As an option it comes with an extra operator platform. The PPX20 model with a maximum speed of 8.5 km/h and the PPXS20 12km/h are equipped with power steering and an operator platform as standard. The CLARK PX range has been designed for the most demanding applications over long transportation distances. The platforms can be manually folded to increase manoeuvrability in confined spaces.

Performance & Safety

- Powerful acceleration with AC technology.
- Battery capacity up to 375Ah.
- Automatic stop on gradients and ramps (automatic parking brake).
- Automatic braking when the tiller handle is released.
- Ergonomic safety tiller arm.
- Side battery removal allows for multiple shift rotation applications. (Option for the PX20 only with a large battery compartment)

Reliability & Servicing

- Error code display in display.
- Reliable AC controller.
- One piece front cover for easy access during service and maintenance work.
- Steel fabricated battery cover (PX20).

Safety & Ergonomics

- Electronic power steering (PPXS20).
- Pedestrian mode 4 km/h travel speed with folded platform and folded side safety guards (PPX(S)20).
- Sensitive drive switch for safe and precise work.
- Suspension support wheel for greater stability (PX20).
- Tiller head integrated drive and operating switches with easy reach positions.
- Clearly positioned battery discharge indicator.
- Sloped battery cover for optimum fork view (PX20).
- Tiller handle crawl speed function (option PX20).

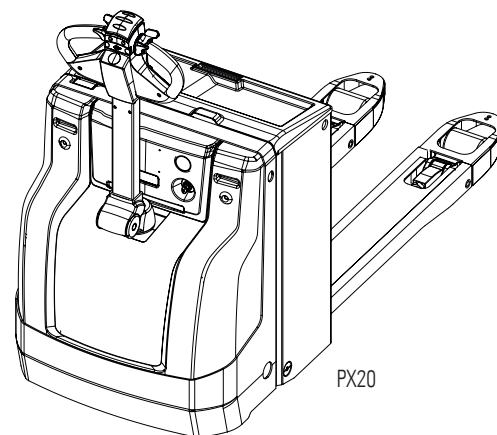
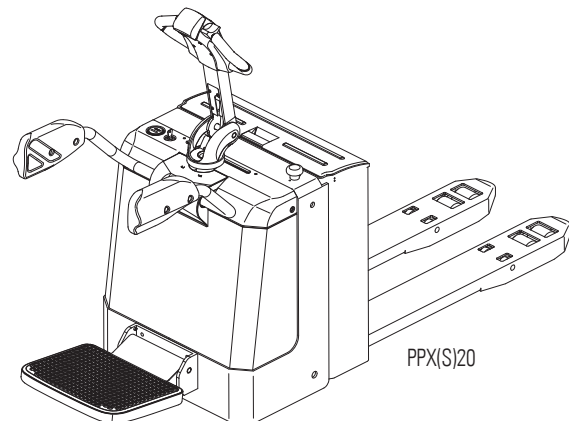

Truck dimensions relative to battery			PX20				
			Battery compartment		Small	Medium	Large
1.9	Wheelbase		y	mm	1356	1430	1495
4.19	Overall length	without platform	l1	mm	1681	1755	1821
		with platform raised/lowered			1775/2181	1849/2255	1914/2320
4.20	Length to face of forks	without platform	l2	mm	531	605	671
		with platform raised/lowered			625/1031	699/1105	764/1170
4.33	Aisle width for pallets 1000 x 1200 sideways	without platform	Ast	mm	2273	2347	2412
		with platform raised/lowered			2367/2773	2441/2847	2506/2912
4.34	Aisle width for pallets 800 x 1200 lengthways	without platform	Ast	mm	2181	2255	2320
		with platform raised/lowered			2275/2681	2349/2755	2414/2820
4.35	Turning radius	without platform	Ast	mm	1536	1610	1675
		with platform raised/lowered			1630/2036	1704/2110	1769/2175

CLARK products, illustrations and specifications are subject to change without notice. Performance may vary +5% and -10% due to motor and system efficiency tolerance.

FEATURES & EQUIPMENT EXTRAS



		PX20	PPX20	PPXS20
General	Reliable low-maintenance AC traction motor	•	•	•
	Two suspension castor wheels	•	-	-
	Load backrest	X	X	X
	Cold storage option (max. -10°)	-	X	X
	Platform option	X	•	•
Drive and Battery Options	Travel speed 6 km/h	•	-	-
	Travel speed 8.5 km/h	-	•	-
	Travel speed 12 km/h	-	-	•
	Single load wheel (Polyurethane)	•	X	X
	Tandem load wheel (Polyurethane)	X	•	•
	Pallet entry wheels	X	X	X
	Electric servo steering	-	-	•
	Profiled traction wheel	-	X	X
	Integrated on-board charger	X	-	-
	Battery discharge indicator	•	•	•
	Side battery removal (PX20 only with 375Ah battery)	X	X	X
	Battery compartment sizes: 150Ah, 250Ah or 375Ah batteries	•	-	-
	Battery compartment sizes: 225Ah, 250Ah or 375 Ah batteries	-	•	•
Miscellaneous	Optional fork length	X	X	X
	Backup alarm	X	-	-
	Crawl speed switch	X	-	-
	Push button for operation with vertical tiller	X	-	-
Safety	Key switch activation	•	•	•
	Pin-code activation	X	-	-
	Automatic lift stop (at max. lift)	•	•	•
	Automatic parking brake	•	•	•
	Comfort and safety tiller	•	•	•
	Control of all drive commands left- and right-handed	•	•	•

• = Standard Equipment; x = Option; - = Not Available

Dealer:

CLARK Europe GmbH
 Dr.-Alfred-Herrhausen-Allee 33
 47228 Duisburg / Germany
 Tel.: +49 (0)2065 499 13-0
 Fax: +49 (0)2065 499 13-290
 E-Mail: Info-europe@clarkmheu.com
 www.clarkmheu.com

No.: 4579629 08/2015