

25LR



218,4 kNm



8,2 bis
10,0 m

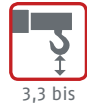

3,3 bis
3,9 m



3,4 bis
5,2 m



2.620 kg



415°



42,0 kNm



220 bar



80 l/min
ca. 64 kW



180 l/min
ca. 83 kW

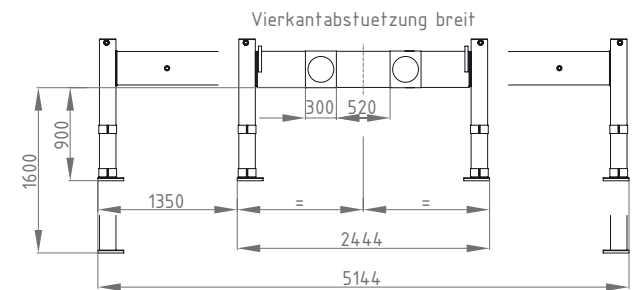
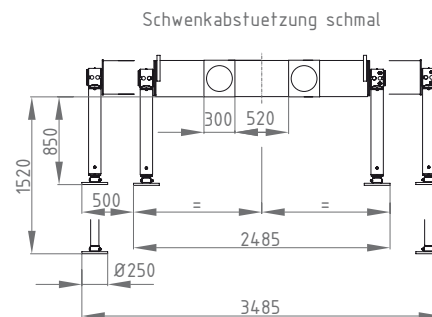
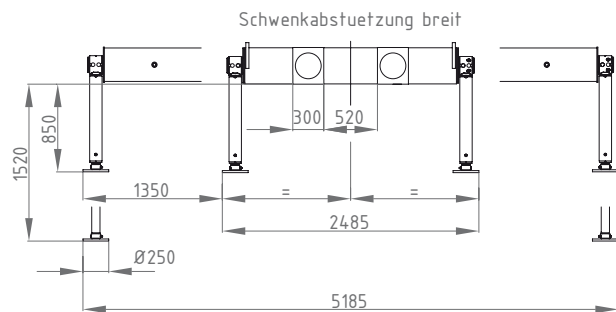
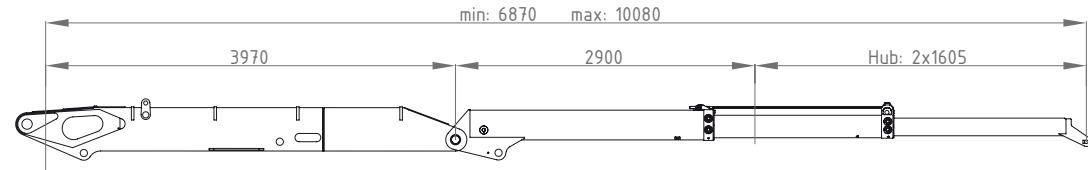
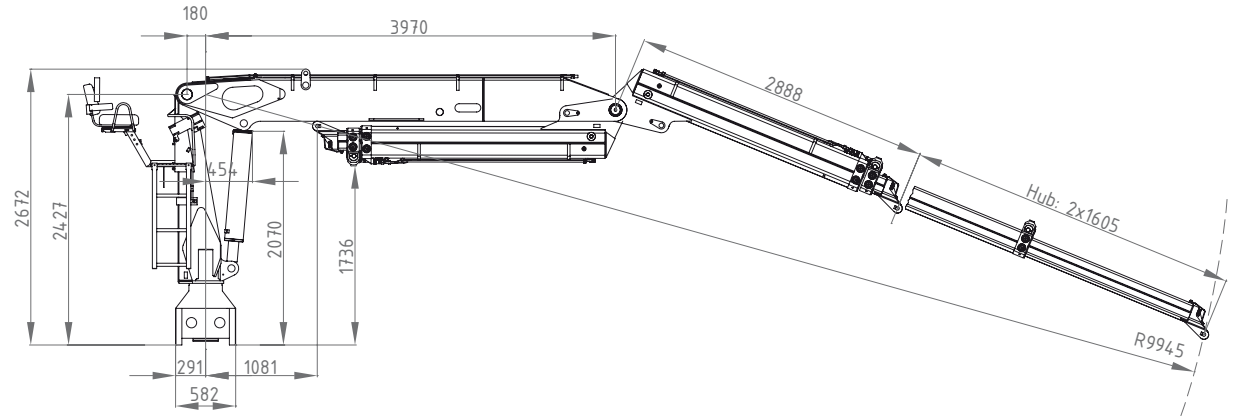
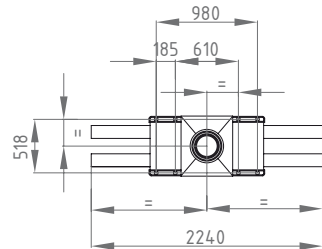
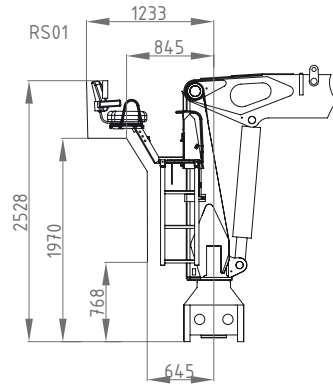

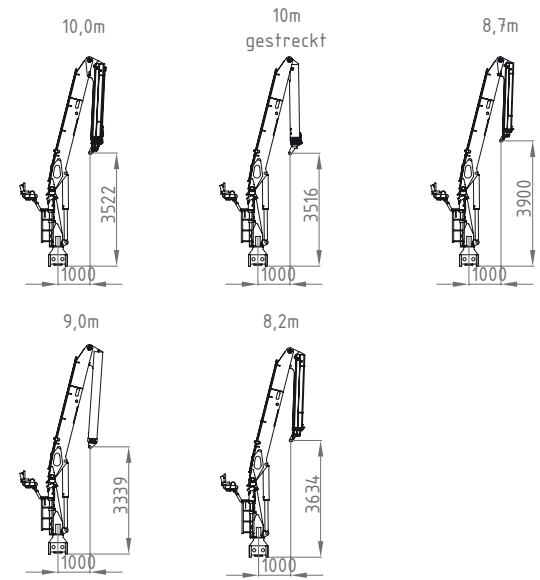
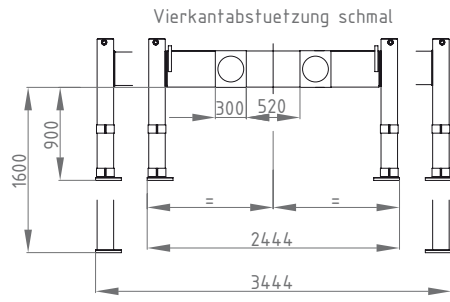
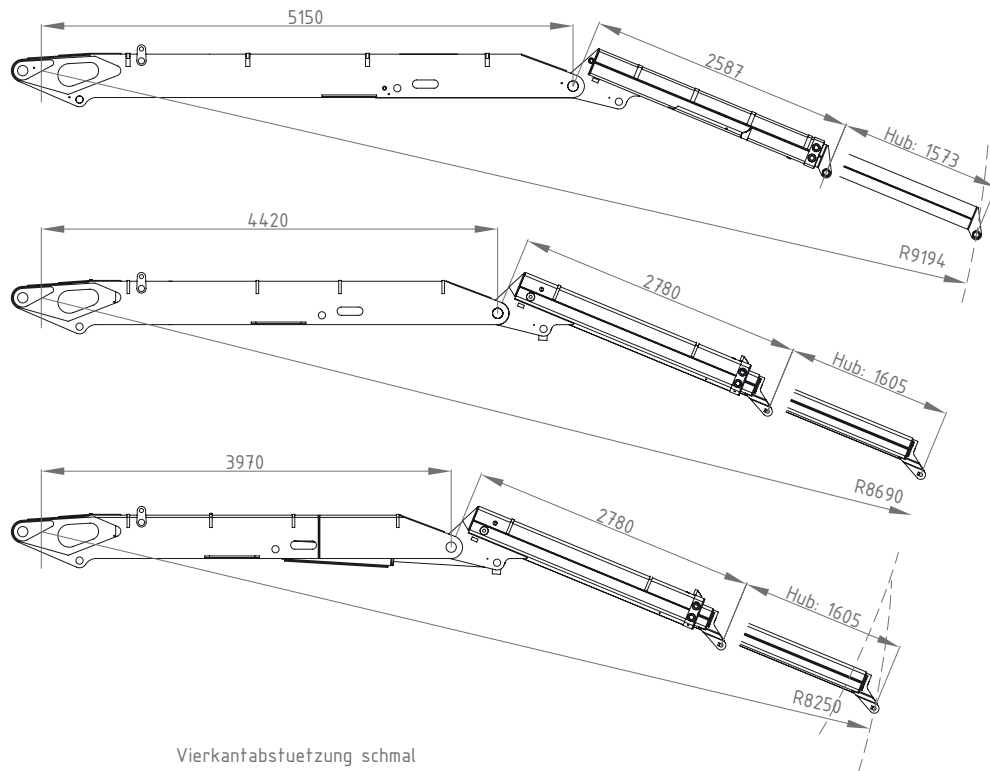

	3m	4m	5m	6m	7m	8m	9m	10m	
8,2m	7460	5600	4480	3730	3195	2760	-	-	kg
8,7m	7375	5530	4428	3690	3160	2730	-	-	kg
9,2m	7355	5520	4405	3680	3152	2725	2420	-	kg
10,0m	7290	5465	4375	3650	3125	2700	2400	2160	kg

gestreckt	10m	3m	4m	5m	6m	7m	8m	9m	10m	
	7290	5465	4375	3650	3125	2700	2400	2160		kg