

DELTA CP AC-evo

The "Forklift Truck" Alternative

Capacity (kg): 600 - 800 - 1000 - 1200 - 1500

Lifting Height (mm): 1600, 2500, 3000, 3500

DELTA CP AC-evo

Easy to use and highly maneuverable with a compact, economical design, the DELTA CP offers all of the advantages of expensive driver-on-board forklifts.

POWER ASSISTED STEERING

AC technology

- + Performance
- + Driving control
- Service Costs



Tilting Mast

A hydraulically powered tilting mast maintains the balance and position of the load in all handling situations.



DRIVING AND TRACTION:

Thanks to power assisted steering (standard on all trucks except 600 kg capacity) the DELTA CP is agile in tight spaces where maneuvering is difficult. AC traction drives offer maximum responsiveness in starting and during braking.



ADJUSTABLE CANTILEVER FORKS:

High strength forged metal forks can be adjusted manually with the FEM fork holder plate to handle non-standard size pallet and containers.



FREEDOM FROM DOWNTIME:

Powered by 24V industrial batteries with capacities to 270 Ah, the DELTA CP offers extended use time between battery charges.



THE "FORKLIFT TRUCK" ALTERNATIVE:

The DELTA CP can be used by any operator with minimal training, without the need for a driver's license required for traditional driver.



No front legs

With no front legs, the DELTA CP can completely fork the pallet and clear any obstacles on the floor.





DELTA CP AC-evo [1600 mm - 2500 mm]

model		60/16	80/16	100/16	120/16	150/16	60/25	80/25	100/25	120/25	150/25
Q	Kg	600	800	1000	1200	1500	600	800	1000	1200	1500
C	mm	600	600	600	600	600	600	600	600	600	600
l	mm	1200	1200	1200	1200	1200	1200	1200	1200	1200	1200
L	mm	2480	2685	2685	2730	2835	2480	2685	2685	2730	2835
X	mm	175	175	175	175	175	175	175	175	175	175
X2	mm	325	325	325	325	325	325	325	325	325	325
Y	mm	780	985	985	985	1135	780	985	985	1070	1135
L2	mm	1280	1485	1485	1485	1635	1280	1485	1485	1580	1635
M	mm	775	775	775	775	775	775	775	775	775	775
N	mm	80	100	100	100	100	80	100	100	100	100
h1	mm	1990	1990	1990	1990	1990	1740	1740	1740	1740	1740
h2	mm	1450	1450	1450	1450	1450	200	200	200	200	200
h3	mm	1550	1550	1550	1550	1550	2450	2450	2450	2450	2450
h4	mm	2100	2100	2100	2100	2100	3020	3020	3020	3020	3020
B	mm	855	855	855	855	855	855	855	855	855	855
WA	mm	1150	1360	1360	1435	1505	1150	1360	1360	1435	1505

STANDARD EQUIPMENT

- Free lift 200 mm • AC three-phase technology traction motors • Electronic battery charger 24V 60A with microprocessor
- Forks control by hydraulic distributor • Hydraulic tilting of the mast • Forged forks length mm. 1150 • Electric end stroke
- Parking Brake • Braking in release contra flow • Side wheels with extra-heavy castors • High-frequency electronic plant 24V with microprocessor fault research • Extruded mast with lateral contrast bearings • Exhausted battery warning-indicator
- DR-EVO Steering • Safety components • Automatic speed reduction • Power assisted steering included (except for capacity 600 kgs.) • Traction Battery 24V 270 Ah

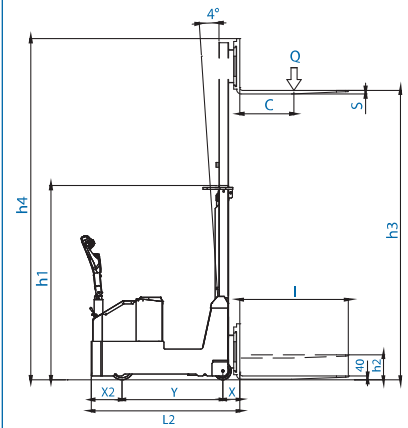
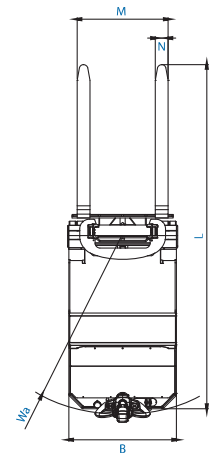

DELTA CP AC-evo [3000 mm - 3500 mm]

model		60/30	80/30	100/30	120/30	150/30	60/35	80/35	100/35	120/35	150/35
Q	Kg	600	800	1000	1200	1500	600	800	1000	1200	1500
C	mm	600	600	600	600	600	600	600	600	600	600
l	mm	1200	1200	1200	1200	1200	1200	1200	1200	1200	1200
L	mm	2480	2685	2685	2730	2835	2480	2685	2685	2730	2835
X	mm	175	175	175	175	175	175	175	175	175	175
X2	mm	325	325	325	325	325	325	325	325	325	325
Y	mm	780	985	985	1070	1135	780	985	985	1070	1135
L2	mm	1280	1485	1485	1580	1635	1280	1485	1485	1580	1635
M	mm	775	775	775	775	775	775	775	775	775	775
N	mm	80	100	100	100	100	80	100	100	100	100
h1	mm	1990	1990	1990	1990	1990	2240	2240	2240	2240	2240
h2	mm	200	200	200	200	200	/	/	/	/	/
h3	mm	2950	2950	2950	2950	2950	3450	3450	3450	3450	3450
h4	mm	3500	3500	3500	3500	3500	4020	4020	4020	4020	4020
B	mm	855	855	855	855	855	855	855	855	855	855
WA	mm	1150	1360	1360	1435	1505	1150	1360	1360	1435	1505

STANDARD EQUIPMENT

- Free lift 200 mm (excluded lifting height mm. 3500) • AC three-phase technology traction motors • Built-in electronic battery charger 24V 60A with microprocessor • Forks control by hydraulic distributor • Hydraulic tilting of the mast • Forged forks length mm. 1150 • Electric end stroke • Parking Brake • Braking in release contra flow • Side wheels with extra-heavy castors
- High-frequency electronic plant 24V with microprocessor fault research • Extruded mast with lateral contrast bearings • Exhausted battery warning-indicator • DR-EVO Steering • Safety components • Automatic speed reduction • Power assisted steering included (except for capacity 600 kgs.) • Traction Battery 24V 270 Ah

