

SE 35

STD



2190 1570 lbs
102" 14'3" ft

35/1

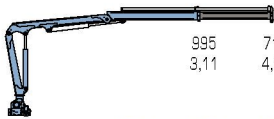

995 710 kg
3,11 4,34 m

2020 2190 1380 1050 lbs
92" 10' 14'5" 18'9" ft

35/2

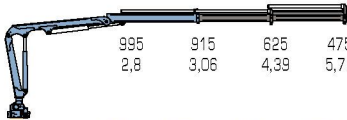

995 915 625 475 kg
2,8 3,06 4,39 5,72 m

2190 1950 1320 990 680 lbs
90" 102" 147" 18'11" 23'4" ft

35/3

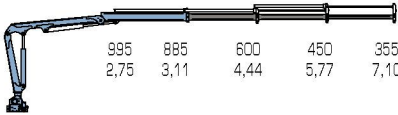

995 885 600 450 355 kg
2,75 3,11 4,44 5,77 7,10 m

SE 37

STD



3360 2190 1570 lbs
6'11" 102" 14'3" ft

37/1

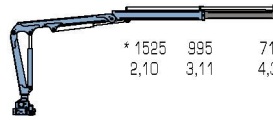

* 1525 995 710 kg
2,10 3,11 4,35 m

2980 2020 1380 1050 lbs
6'11" 100" 14'5" 18'9" ft

37/2

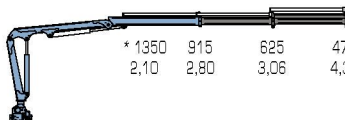

* 1350 915 625 475 kg
2,10 2,80 3,06 4,39 m

2890 2190 2060 1470 1080 820 lbs
6'11" 6'7" 11'2" 15'5" 20'4" 25'3" ft

37/3

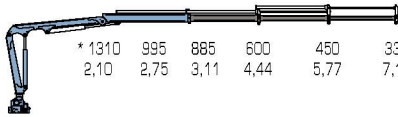

* 1310 995 885 600 450 335 kg
2,10 2,75 3,11 4,44 5,77 7,10 m

* Carico sollevato sul gancio fisso

* Lifting capacity to the fixed hook attachment



METRIC								
35/1	30,36	235	10	420	400	1697x473xh/1576	2,8	3710
35/2	27,47	240	10	455	400	1697x473xh/1576	2,8	3710
35/3	27	240	10	490	400	1724x473xh/1576	2,8	3710

IMPERIAL								
35/1	21959	3408	2,6	930	400	5'7"x17"x5'2"	6160	122"
35/2	19869	3480	2,6	1000	400	5'7"x17"x5'2"	6160	122"
35/3	19529	3480	2,6	1080	400	5'8"x17"x5'2"	6160	122"

METRIC								
37/1	31,4	235	10	420	400	1697x473xh/1576	2,8	3710
37/2	27,8	240	10	455	400	1697x473xh/1576	2,8	3710
37/3	27,01	240	10	490	400	1724x473xh/1576	2,8	3710

IMPERIAL								
37/1	22771	3408	2,6	930	400	5'7"x17"x5'2"	6160	122"
37/2	20188	3480	2,6	1000	400	5'7"x17"x5'2"	6160	122"
37/3	19531	3480	2,6	1080	400	5'8"x17"x5'2"	6160	122"

SE 42 HIGH POWER



42/1

2190	1790	lbs
12'8"	15'5"	ft
995	810	kg
3,85	4,70	m

42/1J1

790	660	lbs
22'8"	27'7"	ft
360	300	kg
6,90	8,40	m

42/2

2190	1700	1280	lbs
12'4"	15'7"	20'4"	ft
995	770	580	kg
3,75	4,74	6,19	m

42/3

2190	1530	1140	900	lbs
11'6"	15'9"	20'6"	25'3"	ft
995	695	515	410	kg
3,5	4,80	6,25	7,70	m

42/4

2190	1470	1080	850	690	lbs
11'2"	15'11"	20'8"	25'5"	30'2"	ft
995	665	490	385	315	kg
3,40	4,84	6,29	7,74	9,19	m



METRIC								
42/1	37,6	295	10	520	400	1784x516xh1633	3,5	4030
42/1J1	37,6	295	10	660	400	1804x662xh1830	3,5	4030
42/2	36,6	295	10	550	400	1784x516xh1633	3,5	4030
42/3	34,2	290	10	585	400	1784x516xh1633	3,5	4030
42/4	33,2	290	10	610	400	1804x516xh1633	3,5	4030

IMPERIAL								
42/1	27196	4278	2,6	1150	400	5'8"x1'7"x5'3"h	7700	13'1"
42/1J1	27196	4278	2,6	1460	400	5'11"x2'0"x6'0"h	7700	13'1"
42/2	26473	4278	2,6	1210	400	5'8"x1'7"x5'3"h	7700	13'1"
42/3	24708	4205	2,6	1290	400	5'8"x1'7"x5'3"h	7700	13'1"
42/4	23999	4205	2,6	1340	400	5'11"x1'8"x5'3"h	7700	13'1"

SE 44 HIGH POWER



44/1

3440	2540	2190	1790	lbs
8'2"	11'1"	12'8"	15'5"	ft
*1560	1150	995	810	kg
2,50	3,39	3,85	4,70	m

44.1J1

790	660	lbs
22'8"	27'7"	ft
360	300	kg
6,90	8,40	m

44/2

3310	2470	2190	1700	1280	lbs
8'2"	10'11"	12'4"	15'7"	20'4"	ft
*1410	1120	995	770	580	kg
2,50	3,34	3,75	4,74	6,19	m

44/3

3110	2360	2190	1530	1140	900	lbs
8'2"	10'9"	11'2"	15'9"	20'6"	25'3"	ft
*1410	995	695	515	410	315	kg
2,50	3,40	4,80	6,25	7,70	9,19	m

44/4

3030	2340	2190	1470	1080	850	690	lbs
8'2"	10'8"	11'2"	15'11"	20'8"	25'5"	30'2"	ft
*1365	1060	995	665	490	385	315	kg
2,50	3,40	4,84	6,29	7,74	9,19	9,19	m



* Carico sollevato sul gancio fisso
* Lifting capacity to the fixed hook attachment

METRIC								
44/1	38,3	295	10	520	400	1784x516xh1633	3,5	4000
44/1J1	38,3	295	10	660	400	1804x662xh1830	3,5	4000
44/2	36,8	295	10	550	400	1784x516xh1633	3,5	4000
44/3	34,6	290	10	585	400	1784x516xh1633	3,5	4000
44/4	33,7	290	10	610	400	1804x516xh1633	3,5	4000

IMPERIAL								
44/1	2770	4278	2,6	1150	400	5'8"x1'7"x5'3"	7700	13'1"
44/1J1	2770	4278	2,6	1460	400	5'11"x2'0"x6'0"	7700	13'1"
44/2	2662	4278	2,6	1210	400	5'8"x1'7"x5'3"	7700	13'1"
44/3	2503	4205	2,6	1290	400	5'8"x1'7"x5'3"	7700	13'1"
44/4	2438	4205	2,6	1340	400	5'11"x1'8"x5'3"	7700	13'1"

SE 55 STD



5340 3090 2250 1760 lbs
6'11" 11'12" 15'11" 19'11" ft

55R/2

2420 1400 1020 800 kg dimensions
2,10 3,65 4,85 6,05 m w 1834 X h 1985



5510 3130 2270 1680 1280 lbs
6'11" 12'4" 16'9" 21'4" 26'3" ft

55/1

2500 1420 1030 760 580 kg
2,10 3,75 5,10 6,50 8,00 m

5340 2980 2140 1650 1280 950 lbs
6'11" 12'6" 17'1" 21'6" 26'3" 31'2" ft

55/2

2420 1350 970 750 580 430 kg
2,10 3,80 5,20 6,55 8,00 9,50 m

880 680 510 lbs
29'2" 33'10" 38'11" ft

55/2J1

400 310 230 kg
8,90 10,30 11,85 m

880 680 440 lbs
29'2" 33'10" 38'11" ft

55/2J2

400 310 200 kg
8,90 10,30 11,85 m

5180 2845 2005 1545 1255 968 726 lbs
6'11" 12'10" 17'3" 21'10" 26'3" 30'10" 35'9" ft

55/3

2350 1290 910 700 570 440 330 kg
2,10 3,90 5,25 6,65 8,00 9,40 10,90 m

5070 2710 1900 1460 1150 930 680 lbs
6'11" 12'11" 17'7" 22'0" 26'7" 31'2" 36'1" ft

55/4

2300 12,30 860 660 520 420 320 kg
2,10 3,95 5,35 6,70 8,10 9,50 10,95 m

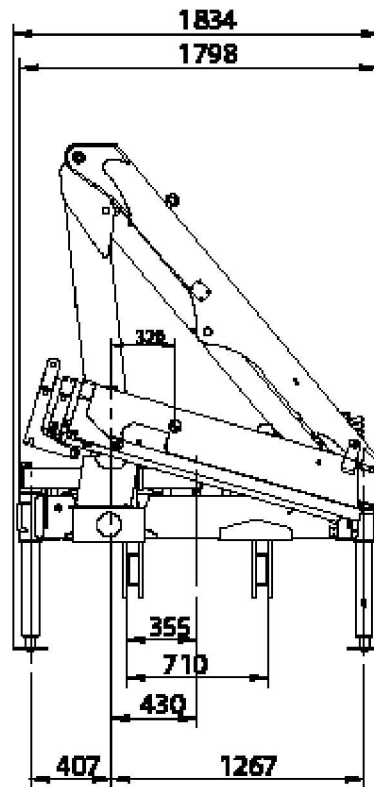

Ingombri versione R
Dimensions R version

METRIC								
55/1	53,2	250	30	775	390	2024x650xh1988	6,5	4200
55/2	51	250	30	825	390	2024x650xh1988	6,5	4200
55/2J1	51	250	30	955	390	2024x690xh1988	6,5	4200
55/2J2	51,3	250	30	990	390	2024x690xh1989	6,5	4200
55/3	50,3	250	30	892	390	2024x650xh1988	6,5	4200
55/4	48,5	250	30	920	390	2020x650xh1988	6,5	4200

IMPERIAL								
55/1	36515	3625	3625	1705	390	6'8"x2'2"x6'6"	14330	13'10"
55/2	36742	3626	3625	1819	390	6'8"x2'2"x6'6"	14330	13'10"
55/2J1	36742	3626	3625	2110	390	7'2"x2'1"x6'2"	14330	13'10"
55/2J2	36742	3626	3625	2190	390	7'2"x2'5"x7'0"	14330	13'10"
55/3	36382	3626	3625	1962	390	7'2"x2'5"x7'0"	14330	13'10"
55/4	35137	3626	3625	1962	390	7'2"x2'1"x6'2"	14330	13'10"

METRIC								
55R/2	51	250	30	780	390	1834x622xh1985	6,5	4200

IMPERIAL								
55R/2	36742	3626	3625	1720	390	6'0"x2'0"x6'6"	14330	13'10"

SE 60

High Power



COMING SOON

5600 3570 2670 lbs
6'7" 10'8" 14'4" ft

60/1

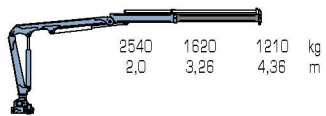

5450 3420 2520 1800 lbs
6'7" 10'10" 14'5" 20' ft

60/2

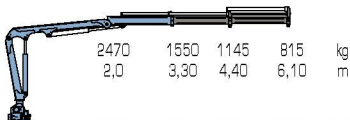

4980 390 2250 1550 1180 lbs
6'7" 10'12" 14'7" 20'2" 25'7" ft

60/3

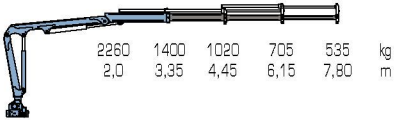

4850 2980 2160 1450 1100 880 lbs
6'7" 11'1" 14'7" 20'4" 25'1" 31'6" ft

60/4

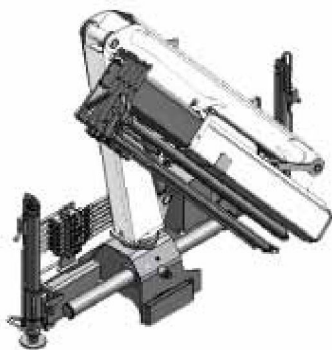
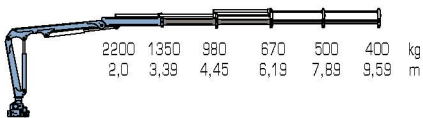

METRIC								
60/1	52	255	15	630	400	1990x630xhx1910	6,5	3700
60/2	50,2	255	15	690	400	1990x630xhx1910	6,5	3700
60/3	46	255	15	745	400	1990x630xhx1910	6,5	3700
60/4	45	255	15	795	400	1990x630xhx1910	6,5	3700

IMPERIAL								
60/1	3747	3698	3,9	1390	400	6'8"x2'2"x6'6"	14330	13'10"
60/2	3631	3698	3,9	1520	400	6'8"x2'2"x6'6"	14330	13'10"
60/3	3327	3698	3,9	1640	400	7'2"x2'5"x7'0"	14330	13'10"
60/4	3313	3698	3,9	1750	400	7'2"x2'1"x6'2"	14330	13'10"

SE 65B

High Power



6830 3700 2570 lbs
6'7" 12'2" 17'3" ft

65B/1

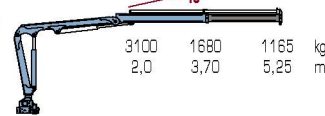

6610 3530 2430 1760 lbs
6'7" 12'6" 17'9" 23'7" ft

65B/2

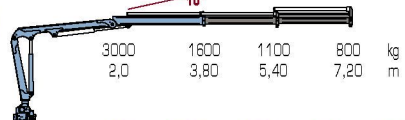

6060 3420 2300 1630 1260 lbs
6'7" 11'8" 17'3" 23'7" 30'2" ft

65B/3

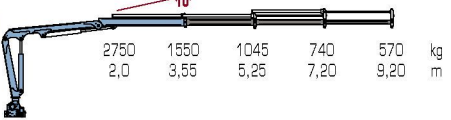

780 620 ... lbs
37'5" 42'4" ... ft

65B/3J1



720 550 330 lbs
37'5" 42'4" 46'11" ft

65B/3J2

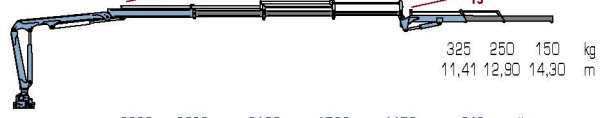

6000 3330 2160 1500 1150 940 lbs
6'7" 11'10" 17'5" 23'7" 30'2" 36'5" ft

65B/4

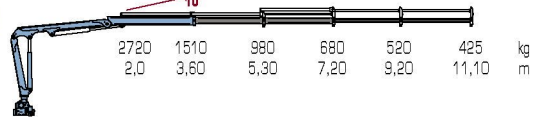

METRIC								
65B/1	59,8	265	20	760	370	2195x627xhx1876	7,5	4500/ 5100
65B/2	57,3	265	20	840	370	2195x627xhx1877	7,5	4500/ 5100
65B/3	55,7	265	20	900	370	2195x627xhx1878	7,5	4500/ 5100
65B/3J1	55,7	265	20	1040	370	2195x733xhx2137	7,5	4500/ 5100
65B/3J2	54	265	20	1070	370	2195x733xhx2137	7,5	4500/ 5100
65B/4	54	265	20	960	370	2195x627xhx1876	7,5	4500/ 5100

IMPERIAL								
65B/1	43253	3843	5,3	1680	370	7'2"x2'1"x6'2"	16535	14'9"/16'11"
65B/2	41445	3843	5,3	1850	370	7'2"x2'1"x6'2"	16535	14'9"/16'11"
65B/3	40288	3843	5,3	1980	370	7'2"x2'1"x6'2"	16535	14'9"/16'11"
65B/3J1	40288	3843	5,3	2290	370	7'2"x2'5"x7'0"	16535	14'9"/16'11"
65B/3J2	40288	3843	5,3	2360	370	7'2"x2'5"x7'0"	16535	14'9"/16'11"
65B/4	39058	3843	5,3	2070	370	7'2"x2'1"x6'2"	16535	14'9"/16'11"

SE 78

HIGH POWER



COMING SOON

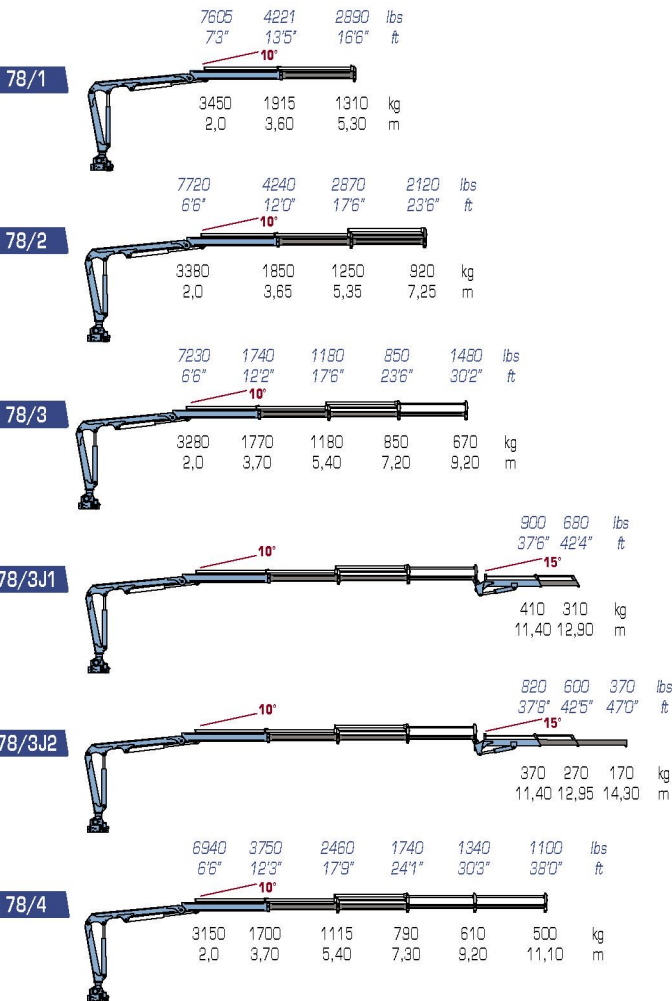

METRIC								
78/1	70.6	290	20	800	370	2195x627xh1876	7.5	4500/5100
78/2	68.93	290	20	870	370	2195x627xh1877	7.5	4500/5100
78/3	64.25	290	20	930	370	2195x627xh1878	7.5	4500/5100
78/3J1	64.25	290	20	970	370	2195x733xh2137	7.5	4500/5100
78/3J2	64.25	290	20	1070	370	2195x733xh2137	7.5	4500/5100
78/4	61.7	290	20	960	370	2195x627xh1876	7.5	4500/5100

IMPERIAL								
78/1	51064	4205	5.3	1760	370	7'2"x2'11"x6'2"h	16535	14'9"/16'11"
78/2	49857	4205	5.3	1920	370	7'2"x2'11"x6'2"h	16535	14'9"/16'11"
78/3	46472	4205	5.3	2050	370	7'2"x2'11"x6'2"h	16535	14'9"/16'11"
78/3J1	46472	4205	5.3	2140	370	7'2"x2'5"x7'0"h	16535	14'9"/16'11"
78/3J2	46472	4205	5.3	2360	370	7'2"x2'5"x7'0"h	16535	14'9"/16'11"
78/4	44627	4205	5.3	2070	370	7'2"x2'11"x6'2"h	16535	14'9"/16'11"

SE 85A

ESSENTIAL

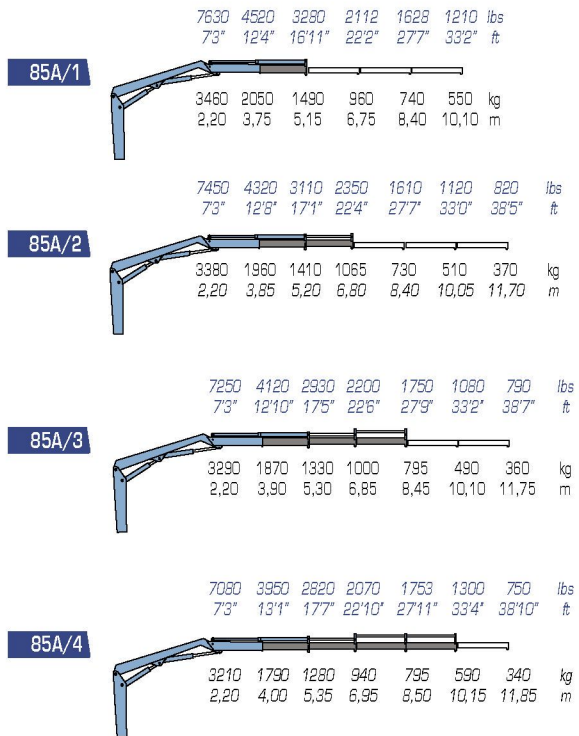

METRIC								
85A/1	75,76	260	25	1010	370	2278x701x2110	8	3256/4426
85A/2	74,09	260	25	1080	370	2278x701x2110	8	3256/4426
85A/3	71,54	260	25	1140	370	2278x701x2110	8	3256/4426
85A/4	70,26	260	25	1195	370	2326x701x2110	8	3256/4426

IMPERIAL								
85A/1	54797	3769	6.6	2230	370	7'6"x2'4"x6'11"	17640	10'8"/146"
85A/2	53599	3769	6.6	2380	370	7'6"x2'4"x6'11"	17640	10'8"/146"
85A/3	51744	3769	6.6	2510	370	7'6"x2'4"x6'11"	17640	10'8"/146"
85A/4	50818	3769	6.6	2630	370	7'8"x2'4"x6'11"	17640	10'8"/146"

SE 85L

ESSENTIAL



7560 4230 3000 2112 1628 1210 lbs
7'3" 13'1" 18'3" 23'5" 28'10" 34'7" ft

85L/1

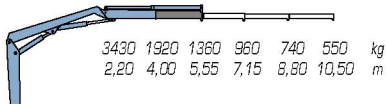

7390 4060 2840 2180 1610 1120 820 lbs
7'3" 13'5" 18'6" 23'7" 28'10" 34'3" 39'8" ft

85L/2

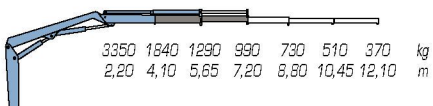

7160 3870 2680 2030 1630 1080 790 lbs
7'3" 13'7" 18'8" 23'9" 29'1" 34'7" 40'0" ft

85L/3

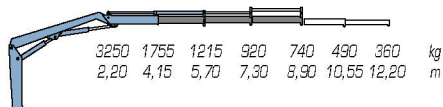

6990 3700 2520 1910 1510 1250 750 lbs
7'3" 13'9" 18'10" 24'1" 29'4" 34'7" 40'6" ft

85L/4

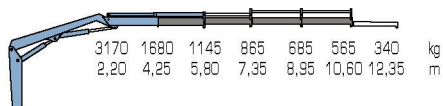

SE 105A

ESSENTIAL



10890 5236 3520 2068 1452 lbs
6'3" 13'1" 18'10" 25'7" 31'5" ft

105A/1

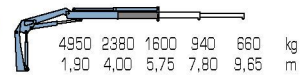

10560 4850 3300 2420 1562 1100 lbs
6'3" 13'5" 19'2" 25'3" 31'10" 38'3" ft

105A/2

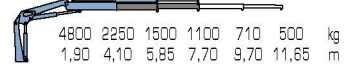

10186 4686 3058 2200 1584 1056 lbs
6'3" 13'9" 19'6" 25'7" 31'10" 38'7" ft

105A/3

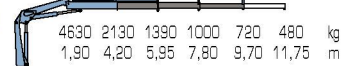

10360 4510 3090 2180 1650 1280 880 lbs
6'5" 14'1" 19'10" 25'10" 32'3" 38'6" 45'3" ft

105A/4

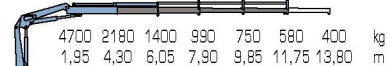

METRIC								
85L/1	71,04	270	25	1040	370	2270x701x2079	8	3256/4426
85L/2	69,7	270	25	1110	370	2270x701x2079	8	3256/4426
85L/3	68,46	270	25	1170	370	2278x701x2079	8	3256/4426
85L/4	65,45	270	25	1220	370	2283x650x2100	8	3256/4426

IMPERIAL								
85L/1	51383	3915	6,6	2290	370	7'5"x2'4"x6'10"	17640	10'8" / 14'6"
85L/2	50413	3915	6,6	2450	370	7'5"x2'4"x6'10"	17640	10'8" / 14'6"
85L/3	49516	3915	6,6	2580	370	7'6"x2'4"x6'10"	17640	10'8" / 14'6"
85L/4	47339	3915	6,6	2690	370	7'6"x2'4"x6'10"	17640	10'8" / 14'6"

METRIC								
105A/1	95,2	290	30	1130	405	2300x640xh2095	12	3,60 std 4,90 XL
105A/2	92,2	290	30	1210	405	2300x640xh2095	12	3,60 std 4,90 XL
105A/3	89,4	290	30	1300	405	2300x640xh2095	12	3,60 std 4,90 XL
105A/4	88,2	290	30	1395	405	2450x650xh2100	12	3,60 std 4,90 XL

IMPERIAL								
105A/1	60612	3914	7,9	2490	405	7'7"x2'1"xh6'10"	26400	10'8"std 14'6"XL
105A/2	59129	3914	7,9	2670	405	7'7"x2'1"xh6'10"	26400	10'8"std 14'6"XL
105A/3	57792	3914	7,9	2865	405	7'7"x2'1"xh6'10"	26400	10'8"std 14'6"XL
105A/4	57792	3914	7,9	3280	405	8'0"x2'2"xh6'11"	26400	10'8"std 14'6"XL