

HA16PE



- Bi-energy (fuel / electric).
- +70° / -70° fly jib.
- 550 lb (250 kg) platform capacity.
- 30 ft (9.1 m) horizontal outreach.
- 6 ft (1.83 m) width.



HA16PE

Articulating Boom

The Haulotte® advantages

- Improved working area through a positive / negative articulating fly jib with 140° movement
- Bi-energy (fuel / electric) allows both inside and outside uses
- Hydraulic differential lock and 10 in (26.5cm) ground clearance for improved rough terrain capability
- Full proportional controls and simultaneous boom functions improve productivity
- 350° turntable rotation
- Zero tailswing
- 180° hydraulic platform rotation
- Compact travel/transport dimensions
- Robust, reliable and easy to maintain design

STANDARD FEATURES

- 2 wheel drive and 4 wheel steer
- Hydraulic brakes
- 45 amp 48 V battery charger
- Load limiter in cage
- 220 V/16 A power line to cage
- 5° tilt alarm
- 12 V Battery / electrical control system
- Emergency hand pump
- Free wheeling device
- Hourmeter
- Slewing block pin
- Towing hooks / lifting eyes

OPTIONS & ACCESSORIES

- Travel / motion alarm
- Rotating beacon
- Working light
- Catalytic exhaust

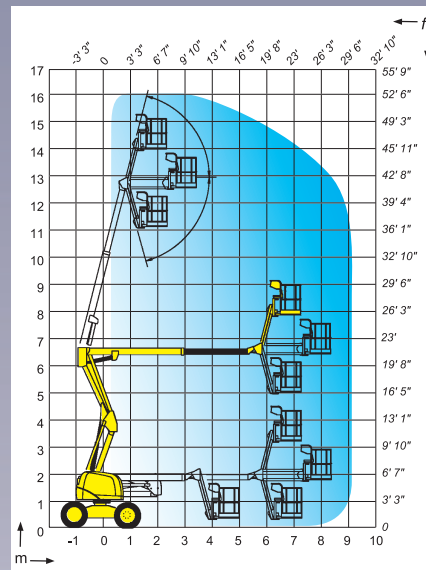
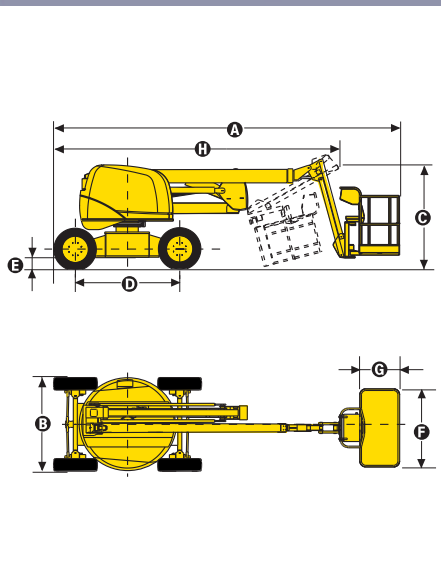

SPECIFICATIONS

Working height	53 ft	16.10 m
Platform height	46 ft et 3 in	14.10 m
Horizontal outreach	30 ft	9.1 m
Up and over clearance	21 ft 4 in	6.5 m
Platform capacity	550 lb	250 kg
Fly jib range of motion	140° (+70° / -70°)	
A Length	21 ft 8 in	6.65 m
B Width	6 ft	1.83 m
C Stowed height	7 ft 2 in	2.2 m
D Wheelbase	6 ft 6 in	2.0 m
E Ground clearance	10 in	26.5 cm
F x G Platform size	59 in x 32 in	1.8m X 0.8m
H Travel/transport length	18 ft	5.50 m
Tailswing	0	0
Drive speed	0.9 / 3.7 mph	1.5 / 6 km/h
Outside turning radius	11 ft 5 in	3.50 m
Turntable rotation	350°	350°
Hydraulic platform rotation	180°	180°
Engine	Diesel Deutz 42hp - 31kW	
Batteries	48V (6 x 8V 375 AH)	
Gradeability	25%	25%
Tyres (Foam Filled)	245/80 - R 19.5	
Hydraulic tank	26 gallons	100 l
Fuel tank	14 gallons	65 l
Weight	17.382 lb	7.885 kg

AS1418.10



HAULOTTE UK LTD • TEL : +44 (0)1952 292753 • www.haulotte-international.com
 HAULOTTE SCANDINAVIA AB • TEL : +46 31 744 32 90 • www.haulotte.se
 HAULOTTE AUSTRALIA PTY LTD • TEL : +61 (0)3 9706 6787 • www.haulotte.com.au
 HAULOTTE SINGAPORE PTE LTD. • TEL : +65 6546 6150 • www.haulotte.sg
 HAULOTTE POLSKA SP. Z.O.O. • TEL : +48 22 885 65 17 • www.haulotte.com.pl

HAULOTTE TRADING (SHANGHAI) CO. LTD. • TEL : +86 21 6288 8228 • www.haulotte.cn
 HAULOTTE NEW ZEALAND • TEL : +64 (0)9 277 6612 • www.haulotte.com.au
 HAULOTTE MIDDLE EAST FZE • TEL : +971 (0)4 299 77 35 • www.haulotte-international.com
 HAULOTTE VOSTOK, OOO • TEL : +7 495 730 0580, +7 962 924 69 80 • www.haulotte-international.com

Haulotte 
 GROUP