



# DELTA AC-evo / DELTA E AC-evo / DELTA UB AC-evo

Strong and Reliable

 Capacity (kg): 1200 - 1500

 Lifting Height (mm): 1600, 2500, 3000, 3500

## DELTA AC-evo

A rugged and reliable stacker for continuous duty pallet handling requirements in medium and large work sites.

### AC technology

- + Performance
- + Driving control
- Service Costs



## DELTA E AC-evo

Version equipped with extruded-metal mast and special steel sections for heavy-duty operations.



Lateral safety boards for the maximum safety of the operator (Optional)



## DELTA UB AC-evo

To increase efficiency and reduce operator fatigue in large work sites, the driver-on-board option allows operator stands on a platform while the truck is in motion.

FULLY POWERED  
STACKERS

Features in detail:



### NEW "DR EVO" DRIVE STEERING:

Includes LED battery charge indicator, "turtle" switch for variable speed control, precision proportional lifting / lowering control and safety reversing (crushproof) switch.



### FREEDOM FROM DOWNTIME:

Powered by 24V industrial batteries with capacities to 270 Ah. A battery charger is built-in to the stacker control housing and includes a 220VAC power cord.



### TRACTION AND STABILITY:

Structure with 5 contact points and shock-absorber system for perfect grip by the driving wheel in case of floor irregularities.

Includes motor-wheel with SEM technology and energy recovery braking system.



### MAINTENANCE:

High frequency 24V microprocessor controls with LED function indicators allow fast and easy troubleshooting. Includes PC control software.



## DELTA AC-evo

model		125/16	155/16	125/25	155/25	125/30	155/30	125/35	155/35
Q	Kg	1200	1500	1200	1500	1200	1500	1200	1500
C	mm	600	600	600	600	600	600	600	600
I	mm	1150	1150	1150	1150	1150	1150	1150	1150
L	mm	1895	1915	1930	1950	1930	1950	1930	1950
X	mm	380	380	415	415	415	415	415	415
X2	mm	175	175	175	175	175	175	175	175
Y	mm	1340	1360	1340	1360	1340	1360	1340	1360
L2	mm	745	765	780	800	780	800	780	800
M	mm	530	530	530	530	530	530	530	530
N	mm	160	160	160	160	160	160	160	160
h1	mm	1990	1990	1740	1740	1990	1990	2240	2240
h2	mm	1450	1450	200	200	200	200	/	/
h3	mm	1600	1600	2500	2500	3000	3000	3500	3500
h4	mm	2120	2120	3020	3020	3520	3520	4020	4020
B	mm	840	840	840	840	840	840	1000*	1000*
WA	mm	1500	1520	1530	1550	1530	1550	1530	1550

### STANDARD EQUIPMENT

• AC three-phase technology traction motors • Free lift 200 mm (excluded lifting height mm. 3500) • Built-in electronic battery charger 24V 30A with microprocessor • Forks control by push-buttons • Fixed forks length mm. 1150 • Electric end stroke • Parking Brake • Braking in release contra flow • Shock absorber on driving-wheel • Side wheels with extra-heavy castors • High-frequency electronic plant 24V with microprocessor fault research • Exhausted battery warning-indicator • DR-EVO Steering • Automatic speed reduction • Safety components • Traction Battery 24V from 160 to 270 Ah

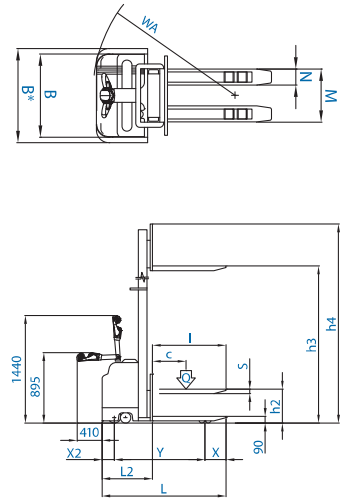

## DELTA E AC-evo

model		125/16	155/16	125/25	155/25	125/30	155/30	125/35	155/35
Q	Kg	1200	1500	1200	1500	1200	1500	1200	1500
C	mm	600	600	600	600	600	600	600	600
I	mm	1150	1150	1150	1150	1150	1150	1150	1150
L	mm	1870	1900	1915	1935	1915	1935	1915	1935
X	mm	375	375	410	410	410	410	410	410
X2	mm	175	175	175	175	175	175	175	175
Y	mm	1330	1330	1330	1330	1330	1330	1330	1330
L2	mm	730	730	765	785	765	785	765	785
M	mm	530	530	530	530	530	530	530	530
N	mm	160	160	160	160	160	160	160	160
h1	mm	1990	1990	1740	1740	1990	1990	2250	2250
h2	mm	1450	1450	200	200	200	200	/	/
h3	mm	1600	1600	2500	2500	3000	3000	3500	3500
h4	mm	2120	2120	3020	3020	3520	3520	4020	4020
B	mm	840	840	840	840	840	840	1000*	1000*
WA	mm	1500	1520	1530	1550	1530	1550	1530	1550

### STANDARD EQUIPMENT

• AC three-phase technology traction motors • Free lift 200 mm (excluded lifting height mm. 3500) • Extruded mast with lateral contrast bearings • Built-in electronic battery charger 24V 30A with microprocessor • Forks control by push-buttons • Fixed forks length mm. 1150 • Electric end stroke • Parking Brake • Braking in release contra flow • Shock absorber on driving-wheel • Side wheels with extra-heavy castors • High-frequency electronic plant 24V with microprocessor fault research • Exhausted battery warning-indicator • DR-EVO Steering • Automatic speed reduction • Safety components • Traction Battery 24V from 160 to 270 Ah

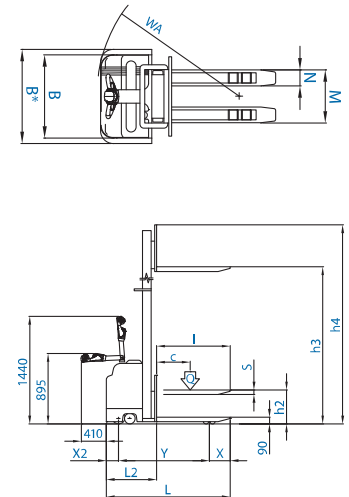

## DELTA UB AC-evo

model		125/16	155/16	125/25	155/25	125/30	155/30	125/35	155/35
Q	Kg	1200	1500	1200	1500	1200	1500	1200	1500
C	mm	600	600	600	600	600	600	600	600
I	mm	1150	1150	1150	1150	1150	1150	1150	1150
L	mm	2000	2020	2035	2055	2035	2055	2035	2055
X	mm	380	380	415	415	415	415	415	415
X2	mm	280	280	280	280	280	280	280	280
Y	mm	1340	1360	1340	1360	1340	1340	1340	1360
L2	mm	850	850	885	885	885	885	885	905
M	mm	530	530	530	530	530	530	530	530
N	mm	160	160	160	160	160	160	160	160
h1	mm	1990	1990	1740	1740	1990	1990	2240	2240
h2	mm	1450	1450	200	200	200	200	/	/
h3	mm	1600	1600	2500	2500	3000	3000	3500	3500
h4	mm	2120	2120	3020	3020	3520	3520	4020	4020
B	mm	840	840	840	840	840	840	1000*	1000*
WA*	mm	2020	2040	2050	2070	2050	2070	2050	2070

### STANDARD EQUIPMENT

• AC three-phase technology traction motors • Free lift 200 mm (excluded lifting height mm. 3500) • Built-in electronic battery charger 24V 30A with microprocessor • Forks control by push-buttons • Fixed forks length mm. 1150 • Electric end stroke • Parking Brake • Braking in release contra flow • Shock absorber on driving-wheel • Side wheels with extra-heavy castors • High-frequency electronic plant 24V with microprocessor fault research • Folding footboard for operator • Exhausted battery warning-indicator • DR-EVO Steering • Automatic speed reduction • Safety components • Traction Battery 24V from 160 to 270 Ah

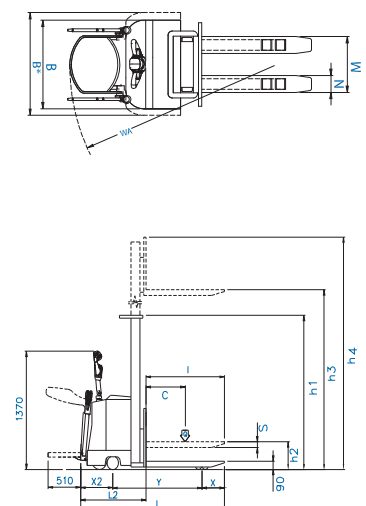

\*Platform close