

Accuracy and precision are its tasks



Technical data

	Lanx Blu
Display	Back-lit LCD 2x16 char
Screen	Ton or kilogram
	Multilingual
Working temperature	0° ÷ 50° C
Power supply	18 ÷ 30 Vdc
Protection level	IP40
Max current	0.5A a 24 Vdc
Dimensions	132x100x42mm without flange
Colour	Metallized blue

Advantages

- Convenient on-board weighing during loading
- No fine for overloading
- Protection against early wear of the vehicle
- Load always within the law limits
- Reusable system
- **Automatic management of an unlimited number of semi-trailers**

The LANX Blu system control unit is installed directly in the cab and provides a real-time display of the net, gross, semi-trailer and tractor axle weights, with the option of partial weights. LANX Blu uses a variety of digital sensors positioned on the vehicle's suspensions and has an alpha-numeric screen that displays all weight data. This has been planned purposely for clients who intend to equip their fleet with a valid weighing system at an extremely competitive price. The system pays for itself immediately because knowing the weight of the load when you travel means optimizing transport times and economic yield in complete safety.



Air or hydraulic suspensions

The digital sensors, which are installed on the tractor rear pneumatic suspensions (1) and on the trailer pneumatic/hydraulic suspensions (2), record the pressure variation due to the weight loaded on the vehicle, by sending data to the LANX unit located in the cab.

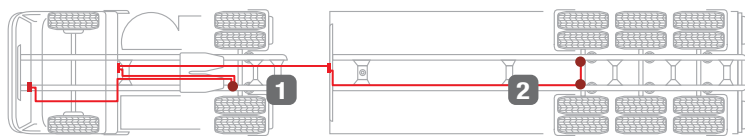

Technical data	Sensor 10 bar	Sensor 160 bar
Range	010 Bar	0160 Bar
Safe overload	150%	150%
Compensated temperature	-20° ÷ +50° C	-20° ÷ +50° C
Protection level	IP65	IP65
Dimensions	145x72x35 mm	145x72x35 mm
Weight	300 gr	400 gr

Accuracy: 0 ÷ 1%

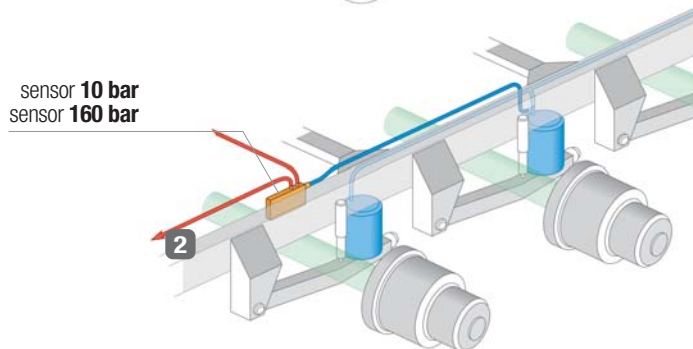
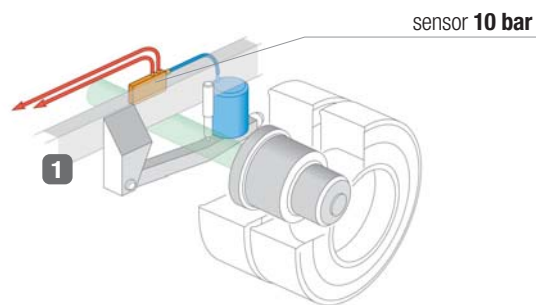

Vehicles with rear dump trailer

The two loading cells located among the dumper rear hinges (2 or 2a) and the pressure sensor installed on the lifting cylinder (1), enable to record the loaded weight by lifting up the dump body a few inches and by sending data to the LANX unit located in the cab.

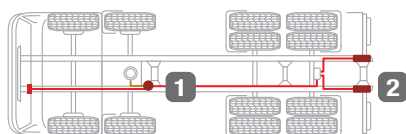

Technical data	Sensor 160 bar
Range	0160 Bar
Safe overload	150%
Compensated temperature	-20° ÷ +50° C
Protection level	IP65
Dimensions	145x72x35 cm
Weight	400 gr

Technical data	10.000 kg	20.000 kg
Loading capacity	10.000 kg	20.000 kg
Safe overload	300%	300%
Compensated temperature	-10° ÷ +50° C	-10° ÷ +50° C
Protection level	IP67	IP67
Dimensions	380x100x39 cm	∅ 60x357 cm
Weight	11,5 kg	8,5 kg

Accuracy: 0 ÷ 0,5%

